



# INDUSTRIAL PRODUCT CATALOGUE



Certified Explosive Boxes



Mine Vehicle Accessories



Drill Rig Accessories



Lifting Equipment



Sandvik Jumbo Accessories

**ELM quality mining products**

# GO DIRECTLY TO THE SOURCE

ELM is a multi-faceted mining services company providing equipment, labour hire and machinery directly to small and medium businesses within the mining industry.



# OUR RANGE

We stock a range of critical mining equipment which are manufactured to the highest Australian standards.



To navigate to a specific product page, simply click on the product name.

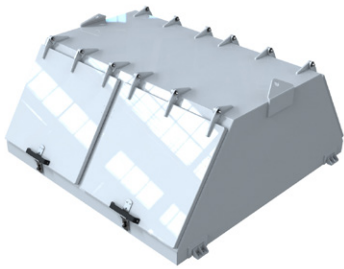

## Certified Explosive Boxes

PRODUCTS AVAILABLE:

1800 X 1800 X 800MM  
EXPLOSIVE BOX

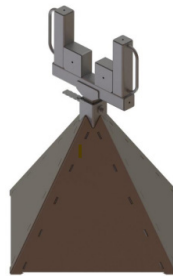

## Drill Rig Accessories

PRODUCTS AVAILABLE:

JUMBO JACK LEG STANDS  
SANDVIK JUMBO BOOM STANDS  
EPIROC M2D RAIL STANDS WITH  
TRAY  
EPIROC M2D RAIL STANDS  
WITHOUT TRAY



## Mine Vehicle Trays

PRODUCTS AVAILABLE:

ROPS CERTIFIED LV TRAY SC LHD  
ROPS CERTIFIED LV TRAY RHD  
ROPS CERTIFIED LV FITTERS TRAY  
ROPS CERTIFIED EXPLOSIVE TRAY  
WITH HEADBOARD  
ROPS CERTIFIED 79 SERIES TRAY  
WITH DROP SIDES  
HILUX SURFACE TRAY

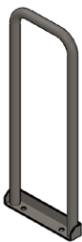

## Mine Vehicle Tray Accessories

PRODUCTS AVAILABLE:

LV FITTERS TRAY – 100L OIL TANK  
LV DRILL STEEL HOLDER  
SINGLE CAB INTRUSION PLATES  
RHD  
STANDARD LV TRAY MUD GUARD  
SET  
TRAY HAND RAIL SET



## Lifting Equipment

PRODUCTS AVAILABLE:

KESSLER LIFTING TOOL  
BUCKET TEETH LIFTING TROLLEY



## Sandvik Jumbo Accessories

PRODUCTS AVAILABLE:

SANDVIK JUMBO HOSE TREE  
LOOM CLAMP  
SANDVIK JUMBO HOSE LOOM  
HANGER CLAMP



# CERTIFIED EXPLOSIVE BOXES



1800 X 1800 X 800MM EXPLOSIVES BOX

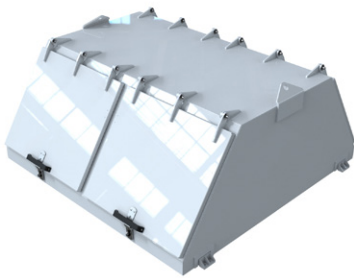

ELM certified Lockable Explosive Transport Boxes are meticulously engineered to meet all requirements for Category 2 mixed loads of explosives as outlined in the Australian Code for the Transport of Explosives by Road and Rail- Third Edition (2009) (Section 7.3.2). These boxes offer a secure and compliant solution for explosive transport on certified light vehicle trays. Featuring three separate internal compartments, the design ensures the necessary segregation of detonators Class (1.1B) and Explosives Class (1.1D). These boxes are constructed with a maximum working load limit of 500KG for explosives and 20KG for detonators, ensuring safe and efficient operations. The internal structure consists of approved 70mm hardwood, securely fixed to a 3mm plate, eliminating any potential for incendiary sparks.

## Features:

- ◆ Complete lockability with rated hinges made from anodized steel
- ◆ All internal components are constructed using approved materials to prevent incendiary sparks
- ◆ All welds and testing adhere to AS 1665
- ◆ Completely weatherproof to withstand the elements
- ◆ Continuous floor to effectively contain potential spillage
- ◆ Meets all Class 2 requirements in the Australian code for the transport of explosives by road or rail

SERIES	MATERIAL	FINISH	WEIGHT	DIMENSIONS (MM)	CERTIFICATION
2275-130VNTP	Aluminium	Painted/White	273.1 Kg	1800 x 1800 x 800mm	Third Edition (2009) (Section 7.3.2)

## Engineering & Dimensions

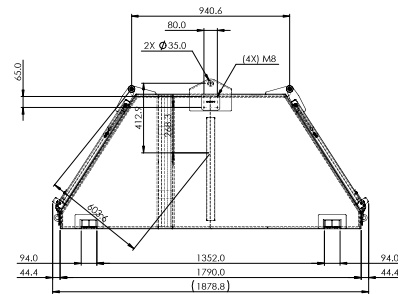
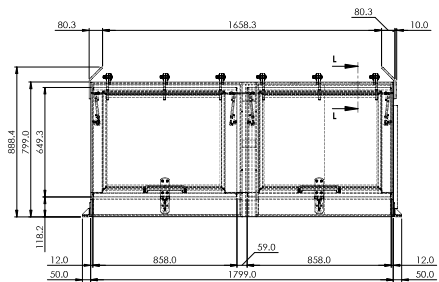
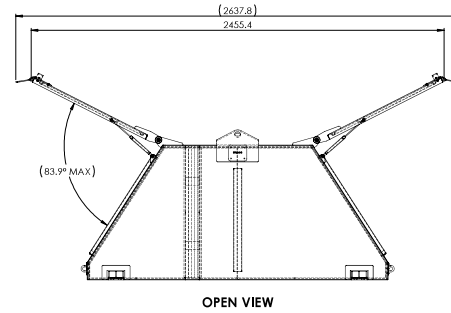
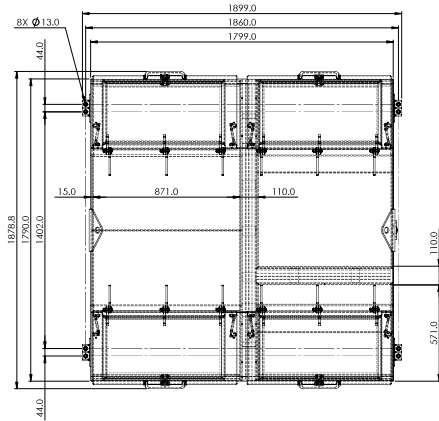

# DRILL RIG ACCESSORIES

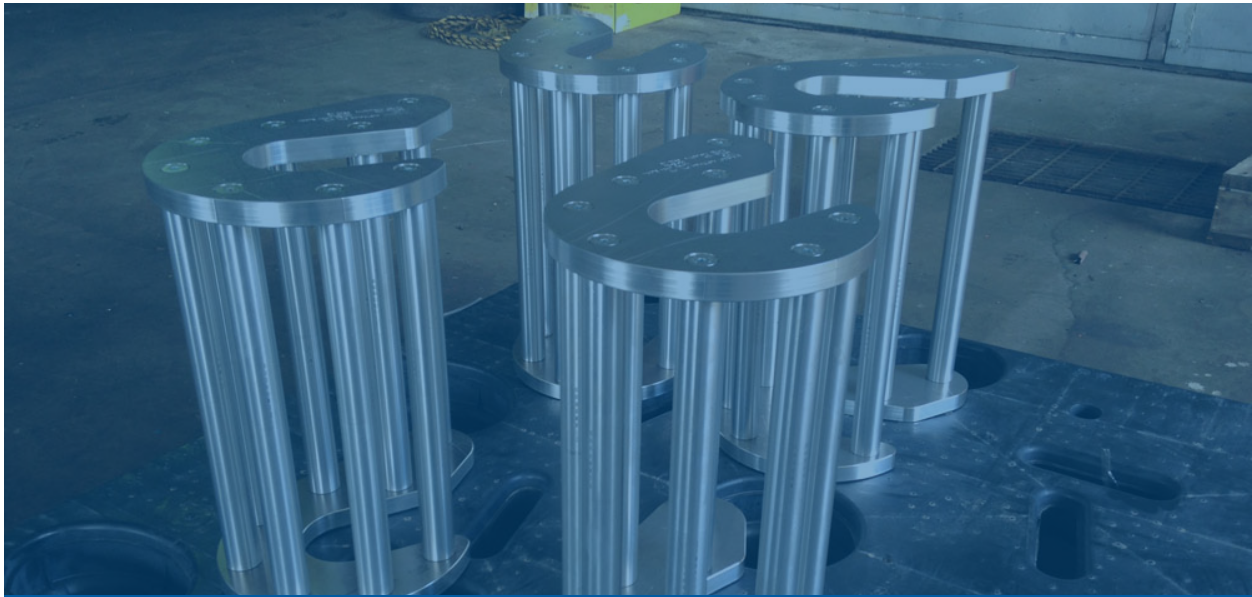

## JUMBO JACK LEG STANDS

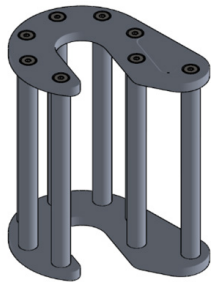

ELM's engineered and certified Jumbo Jack Leg Stands are the ultimate solution for enhancing safety and efficiency during Jumbo servicing and repairs. Crafted from lightweight yet robust aluminium, these stands not only eliminate the risk of uncontrolled machine movement but also provide ease of mobility, reducing manual handling. Weighing just 9.3KG, each stand is easily manoeuvrable and adjustable.

For a safer and more streamlined maintenance process, these jumbo jack leg stands are the perfect choice.

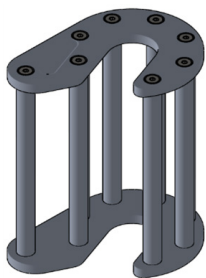

### Features

- ◆ Capacity rating of 9,500 KG per stand
- ◆ Fully engineered and certified
- ◆ Crafted from robust yet lightweight aluminum to facilitate effortless handling and lifting

SERIES	MATERIAL	FINISH	WEIGHT	DIMENSIONS (MM)	CERTIFICATION
2275-110S1	Aluminium	Raw	9.3 Kg	311.7 x 231 x 383.6	AS 1664 AS 1665

## Engineering & Dimensions

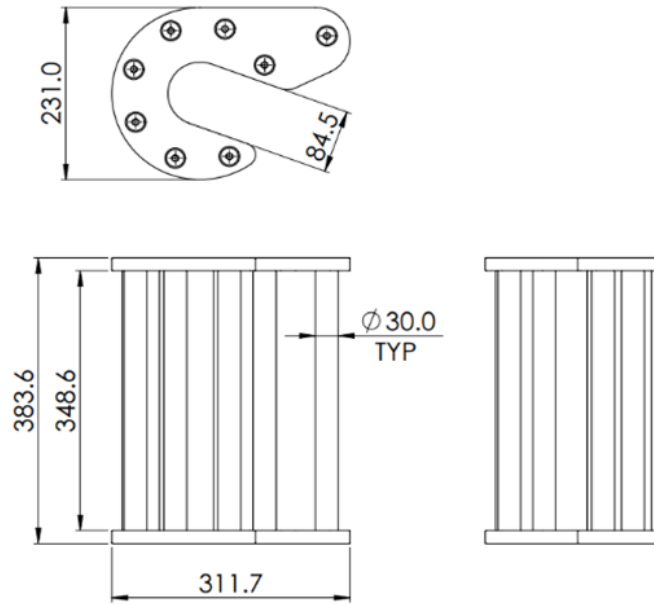

# DRILL RIG ACCESSORIES

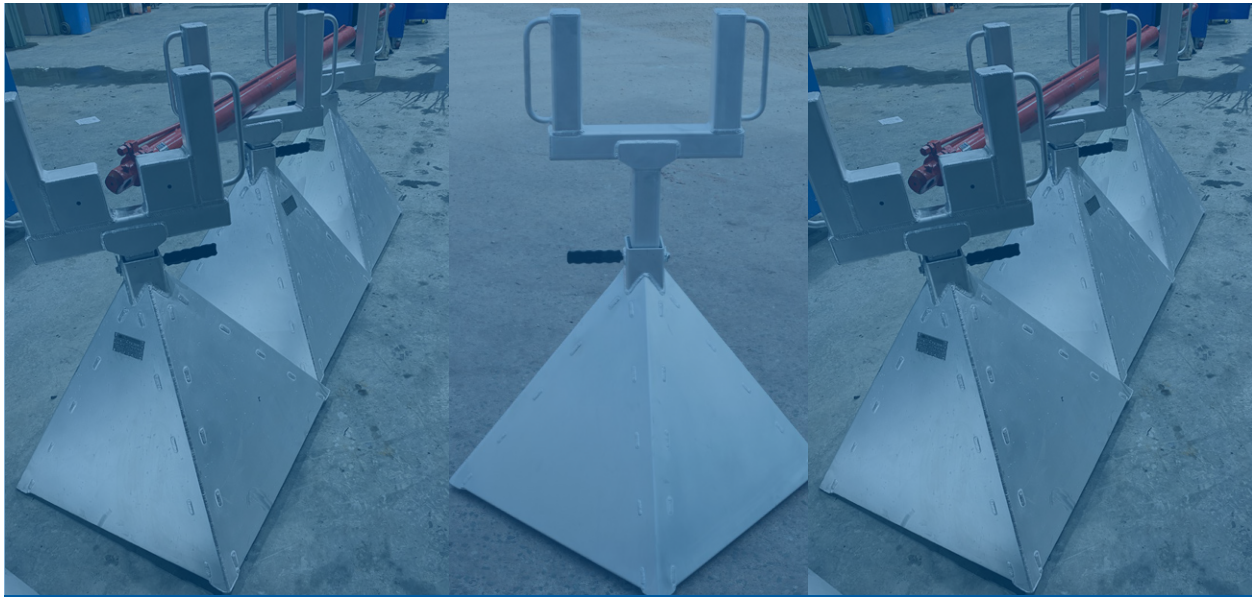

## SANDVIK JUMBO BOOM STANDS

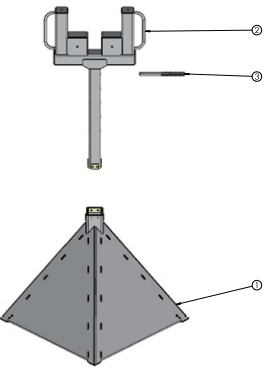
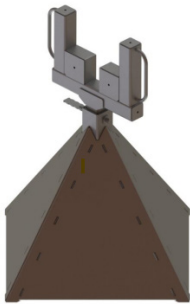

ELM certified Jumbo Boom Stands provide safety and efficiency in service and repairs. Crafted from durable aluminum and weighing 44.4KG, these stands are designed to eliminate the potential for uncontrolled boom movement during service works. In addition, inbuilt castor wheels ensure effortless maneuverability on any workshop surface. The integration of the feed rail slot within the stand eliminates the need for cumbersome tie-down straps or chains. These stands are the ideal choice for seamless and safe maintenance work on Jumbo drills.

### Features

- ◇ Capacity rating of 850 KG per stand
- ◇ Adjustable cradle to achieve more working clearance
- ◇ Tested to AS 1544
- ◇ Construction adheres to AS 4100
- ◇ Fully engineered and certified

### Available Packages:

- ◇ Single stand, Set of 2, Set of 4

SERIES	MATERIAL	FINISH	WEIGHT	DIMENSIONS (MM)	CERTIFICATION
2275-140	Aluminium	N/A	44.4 Kg	816 x 816 x 1165.5	AS 1544 AS 4100



## Engineering & Dimensions

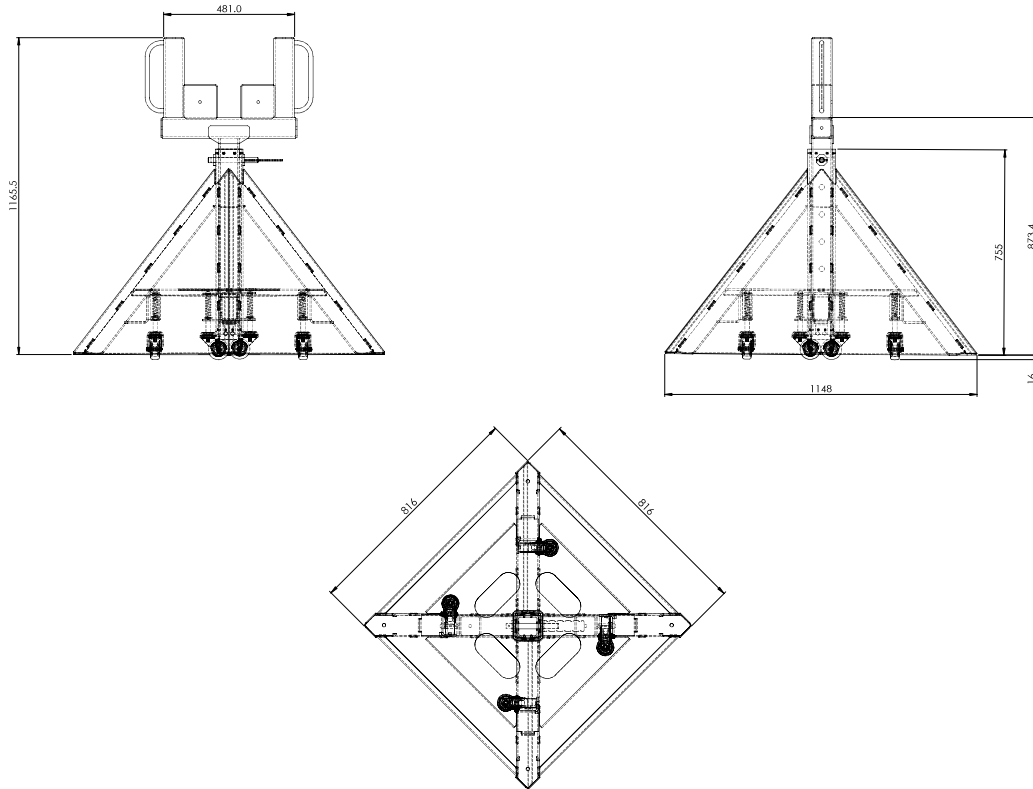

# DRILL RIG ACCESSORIES



## EPIROC M2D RAIL STANDS WITH TRAY

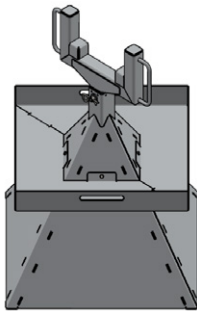

ELM certified Epiroc M2D Rail Stands provide safety and efficiency in service and repairs. Crafted from durable aluminum and weighing 66KG, these stands are designed to eliminate the potential for uncontrolled rail movement during service works. In addition, inbuilt caster wheels ensure effortless maneuverability on any workshop surface. The integration of the feed rail slot within the stand eliminates the need for cumbersome tie-down straps or chains. These stands are the ideal choice for seamless and safe maintenance work on Epiroc M2D drills.

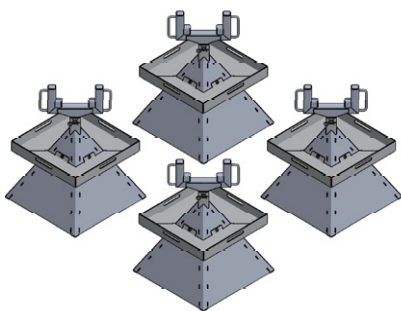

### Features

- ◇ Capacity rating of 850 KG per stand
- ◇ Adjustable cradle to achieve more working clearance
- ◇ Tested to AS 1544
- ◇ Construction adheres to AS 4100
- ◇ Fully engineered and certified
- ◇ Catch tray for spillage/storage of tools

### Available Packages:

- ◇ Single stand, Set of 2, Set of 4

SERIES	MATERIAL	FINISH	WEIGHT	DIMENSIONS (MM)	CERTIFICATION
2275-271-18	Aluminium	Chemically Cleaned Aluminium	66 Kg	998 x 998 x 1335.7	AS 1544 AS 4100

## Engineering & Dimensions

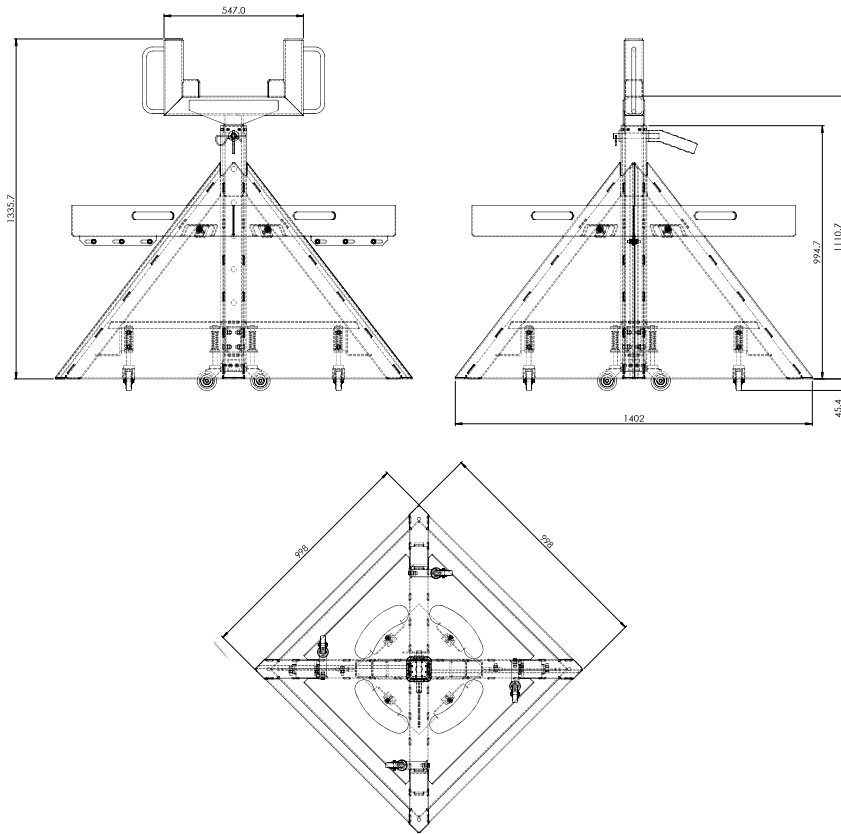

# DRILL RIG ACCESSORIES



## EPIROC M2D RAIL STANDS WITHOUT TRAY

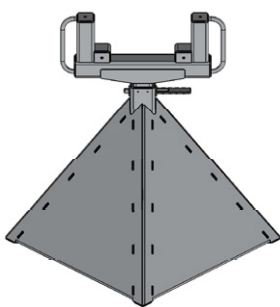
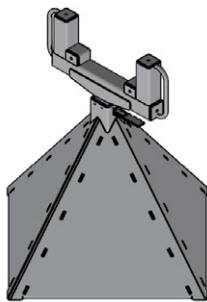

ELM certified Epiroc M2D Rail Stands provide safety and efficiency in service and repairs. Crafted from durable aluminum and weighing 43.6KG, these stands are designed to eliminate the potential for uncontrolled rail movement during service works. In addition, inbuilt caster wheels ensure effortless maneuverability on any workshop surface. The integration of the feed rail slot within the stand eliminates the need for cumbersome tie-down straps or chains. These stands are the ideal choice for seamless and safe maintenance work on Epiroc M2D drills.

### Features

- ◇ Capacity rating of 850 KG per stand
- ◇ Adjustable cradle to achieve more working clearance
- ◇ Tested to AS 1544
- ◇ Construction adheres to AS 4100
- ◇ Fully engineered and certified

### Available Packages:

- ◇ Single stand, Set of 2, Set of 4

SERIES	MATERIAL	FINISH	WEIGHT	DIMENSIONS (MM)	CERTIFICATION
2275-271	Aluminium	Chemically Cleaned Aluminium	43.6 Kg	816 x 816 x 1065.99	AS 1544 AS 4100

## Engineering & Dimensions

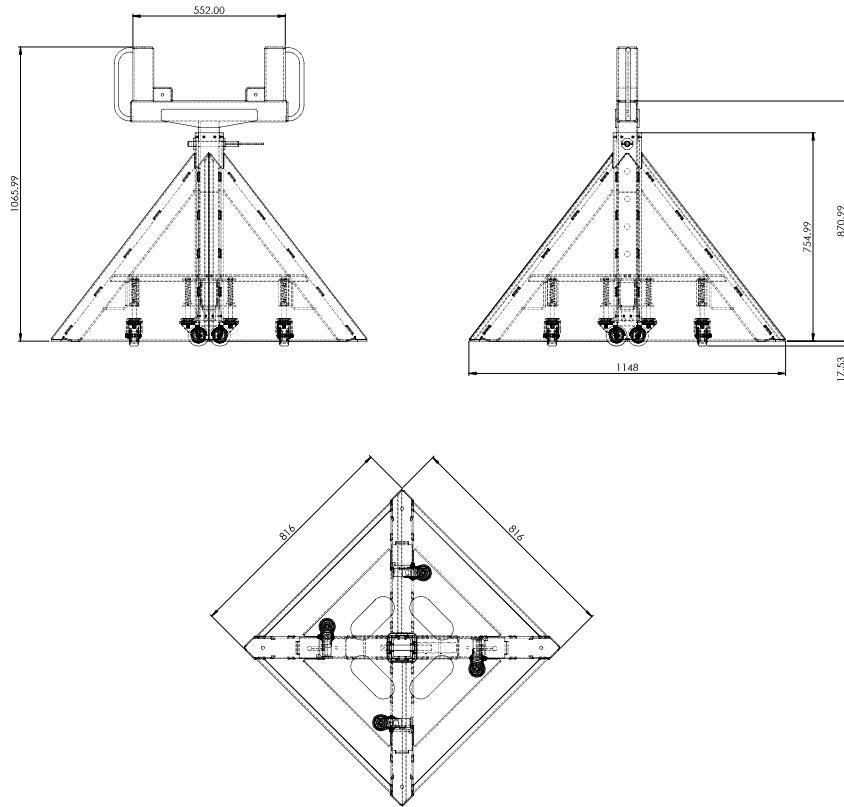

# MINE VEHICLE TRAYS



## ROPS CERTIFIED LV TRAY SC LHD



The ELM Light Vehicle Tray is compliant to ISO 3471:2008 and is ROPS certified. This product is meticulously engineered to withstand the demanding conditions of underground operations. This is achieved through the incorporation of an angled rear tray body, which is entirely hot-dipped galvanized for exceptional durability and resilience. This product suits a single cab left hand drive Toyota LandCruiser.

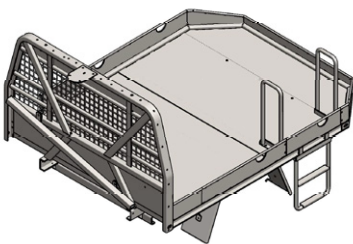

### Features

- ◇ ISO 3471:2008 ROPS certified
- ◇ Hot dip galvanized
- ◇ Handrail kit included
- ◇ Direct bolt on to Toyota LandCruiser vehicles
- ◇ Mud guard kit included
- ◇ Spare wheel bracket
- ◇ Step ladder included
- ◇ Scaling bar holder included

SERIES	MATERIAL	FINISH	WEIGHT	DIMENSIONS (MM)	CERTIFICATION
2275-192	Mild Steel	Hot Dip Galvanized	391 Kg	2515.6 x 1880 x 1699.5	ISO 3471:2008

## Engineering & Dimensions

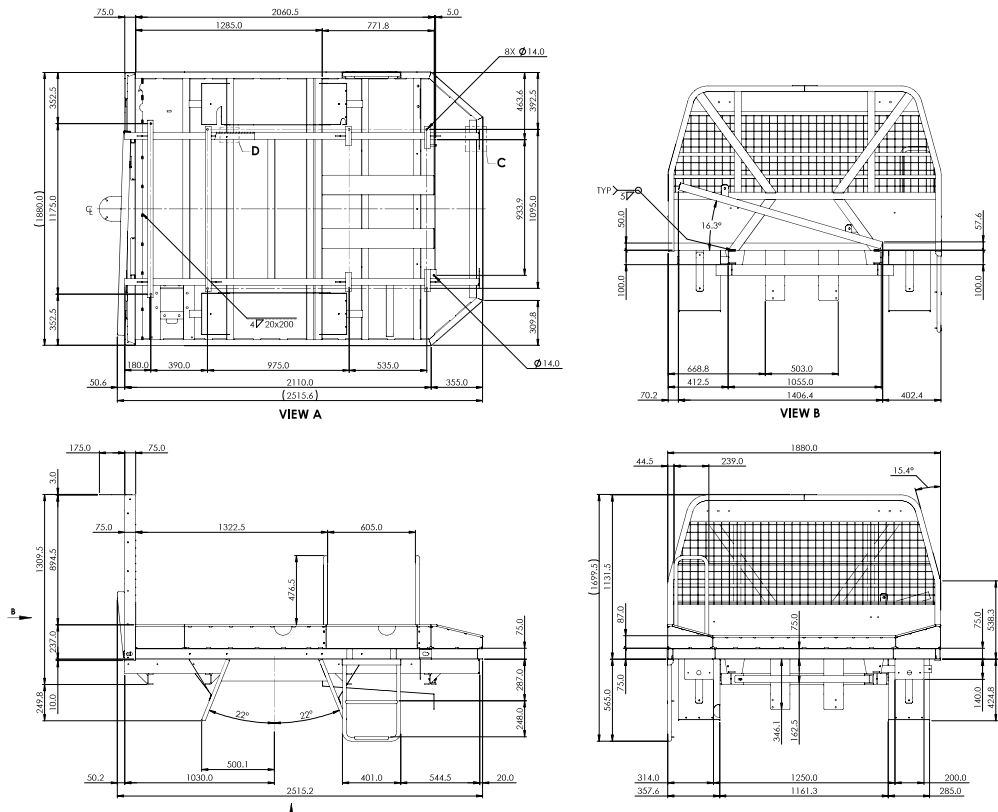

# MINE VEHICLE TRAYS



**ROPS CERTIFIED LV TRAY RHD**

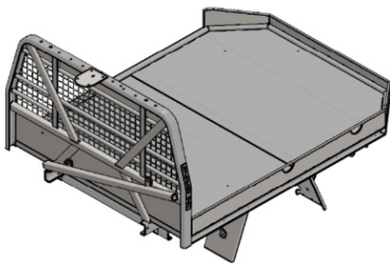

The ELM Light Vehicle Tray is compliant to ISO 3471:2008 and is ROPS certified. This product is meticulously engineered to withstand the demanding conditions of underground operations. This is achieved through the incorporation of an angled rear tray body, which is entirely hot-dipped galvanized for exceptional durability and resilience. This product suits a single cab right hand drive Toyota LandCruiser.

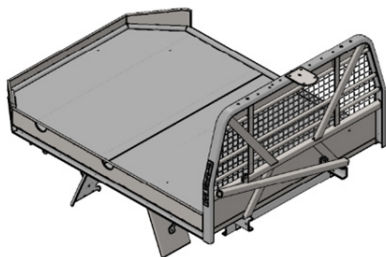

## Features

- ◇ ISO 3471:2008 ROPS certified
- ◇ Hot dip galvanized
- ◇ Handrail kit included
- ◇ Direct bolt on to Toyota LandCruiser vehicles
- ◇ Mud guard kit included
- ◇ Spare wheel bracket
- ◇ Step ladder included
- ◇ Scaling bar holder included

SERIES	MATERIAL	FINISH	WEIGHT	DIMENSIONS (MM)	CERTIFICATION
2275-215	Mild Steel	Hot Dip Galvanized	350 Kg	2465 x 1883.5 x 1559.3	ISO 3471:2008



## Engineering & Dimensions

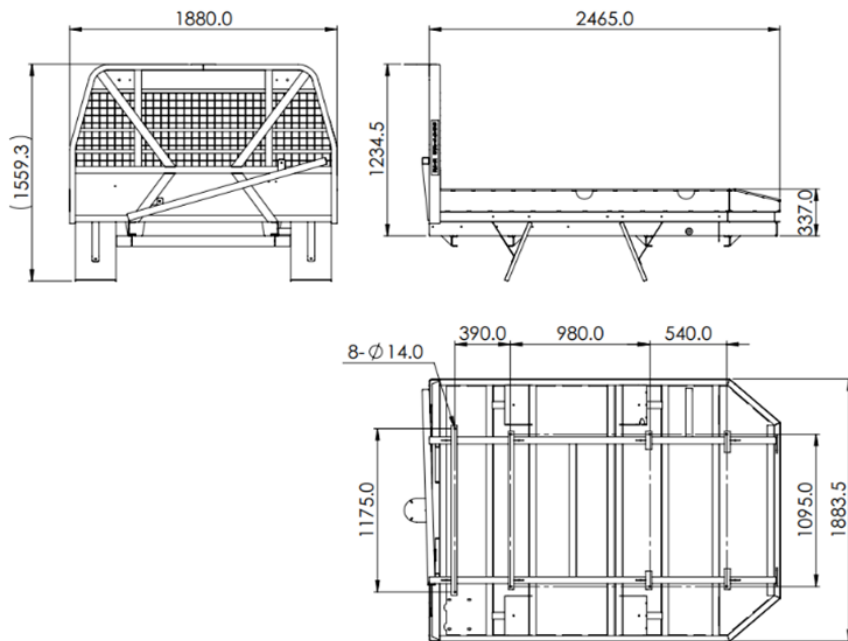

# MINE VEHICLE TRAYS

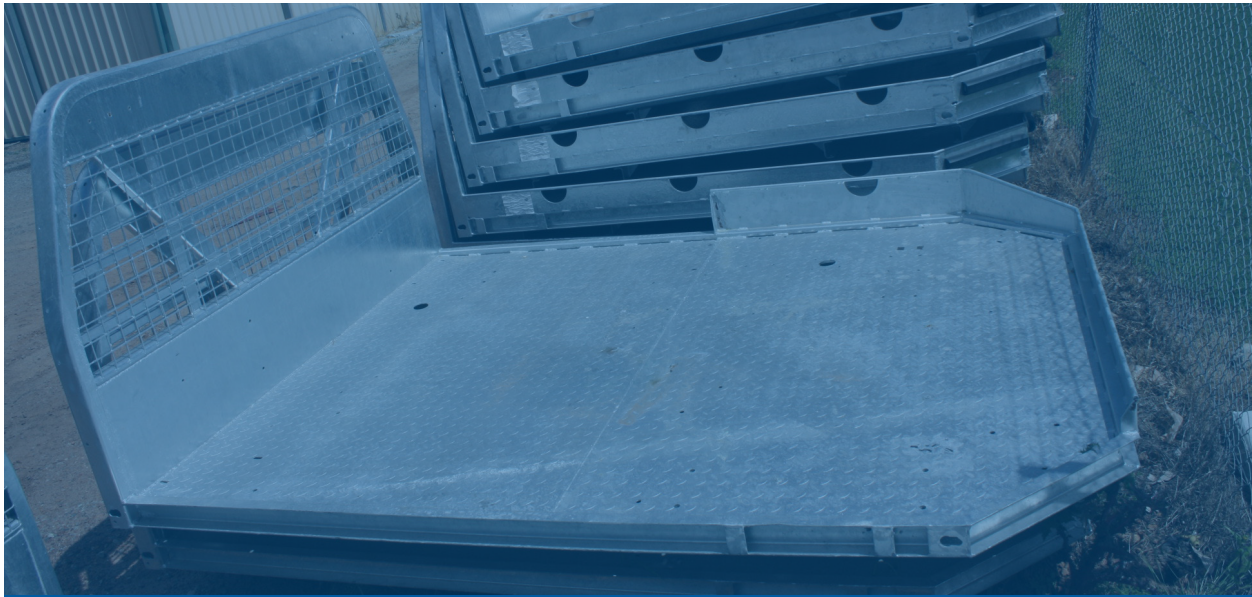

## ROPS CERTIFIED LV FITTERS TRAY

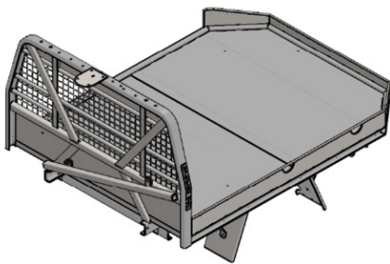

The ELM Light Vehicle Fitters Tray is compliant to ISO 3471:2008 and is ROPS certified. This product is meticulously engineered to withstand the demanding conditions of underground operations. This is achieved through the incorporation of an angled rear tray body, which is entirely hot-dipped galvanized for exceptional durability and resilience. To allow for easy customisation, this tray comes with pre-drilled mounting points for common fitter accessories such as toolboxes, grease drums and more.

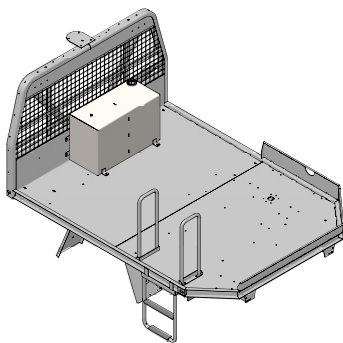

### Features

- ◇ ISO 3471:2008 ROPS certified
- ◇ Hot dip galvanized
- ◇ Handrail kit included
- ◇ Direct bolt on to Toyota LandCruiser vehicles
- ◇ Mud guard kit included
- ◇ Spare wheel bracket
- ◇ Step ladder included
- ◇ Scaling bar holder included
- ◇ Pre-drilled mounting points for common fitter accessories

SERIES	MATERIAL	FINISH	WEIGHT	DIMENSIONS (MM)	CERTIFICATION
2275-192VFT	Mild Steel	Hot Dip Galvanized	394 Kg	2565.2 x 1880 x 1709.5	ISO 3471:2008

## Engineering & Dimensions

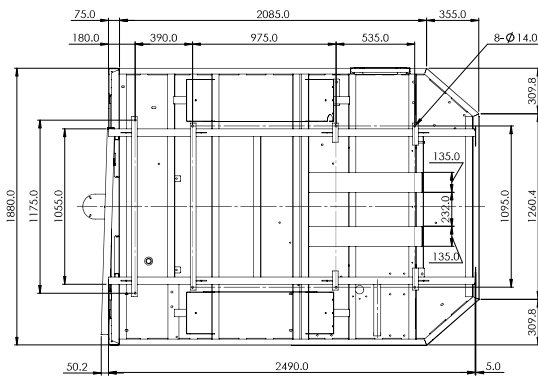
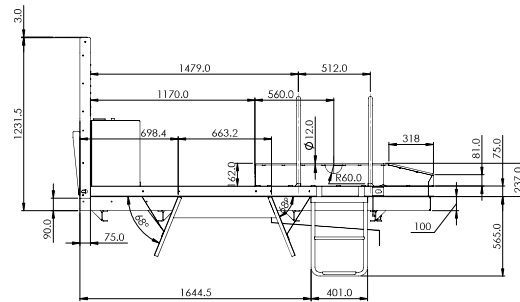
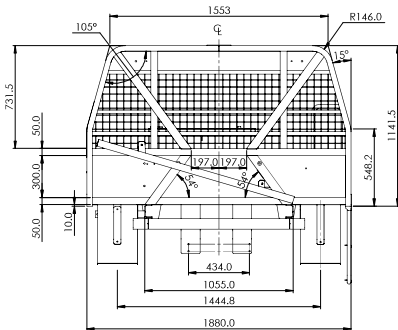

# MINE VEHICLE TRAYS

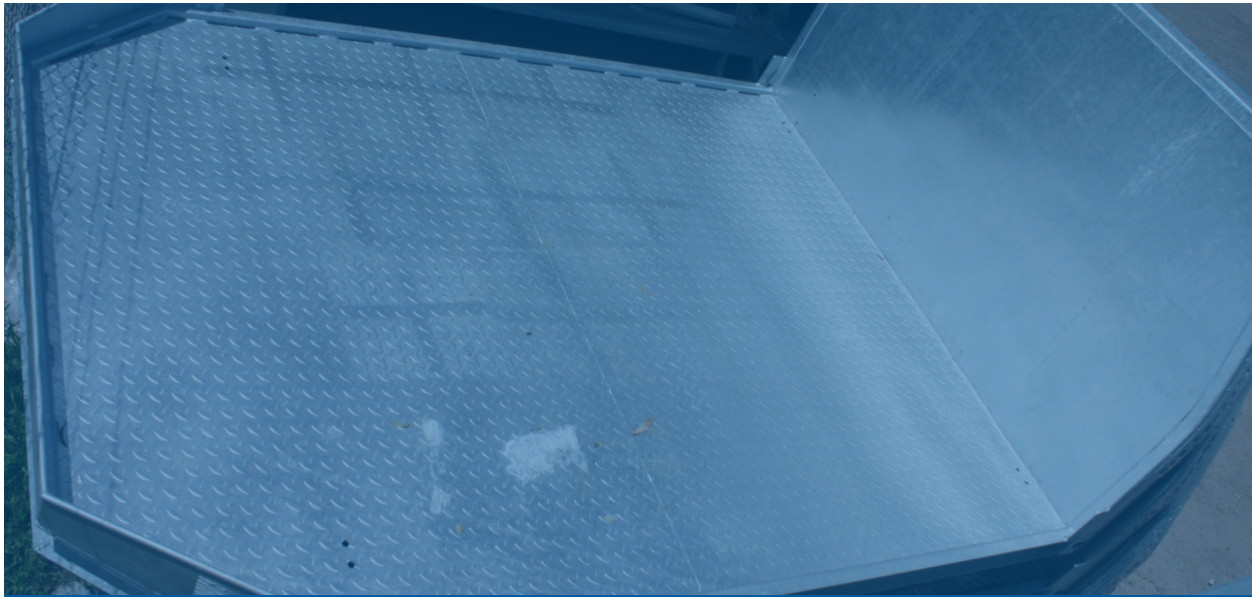

**ROPS CERTIFIED EXPLOSIVE TRAY WITH HEADBOARD**

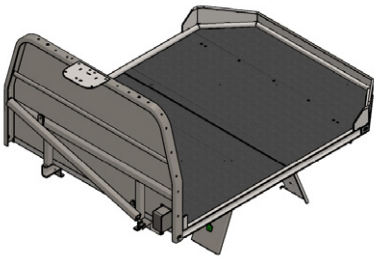

The ELM Light Vehicle Explosives Tray is compliant to ISO 3471:2008 and is ROPS certified. This product is meticulously engineered to withstand the demanding conditions of underground operations. This is achieved through the incorporation of an angled rear tray body, which is entirely hot-dipped galvanized for exceptional durability and resilience. To ensure complete cab protection, this tray is constructed with a solid blast protection headboard.

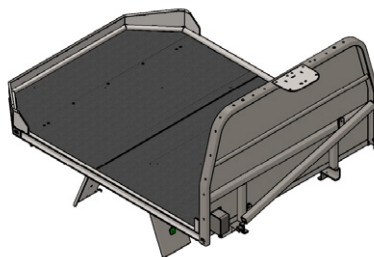

## Features

- ◇ ISO 3471:2008 ROPS certified
- ◇ Hot dip galvanized
- ◇ Direct bolt on to Toyota LandCruiser vehicles
- ◇ Mud guard kit included
- ◇ Solid headboard for complete cab protection

SERIES	MATERIAL	FINISH	WEIGHT	DIMENSIONS (MM)	CERTIFICATION
000124VNTP	Mild Steel	Hot Dip Galvanized	329.4 Kg	2465 x 1880 x 1559.3	ISO 3471:2008

## Engineering & Dimensions

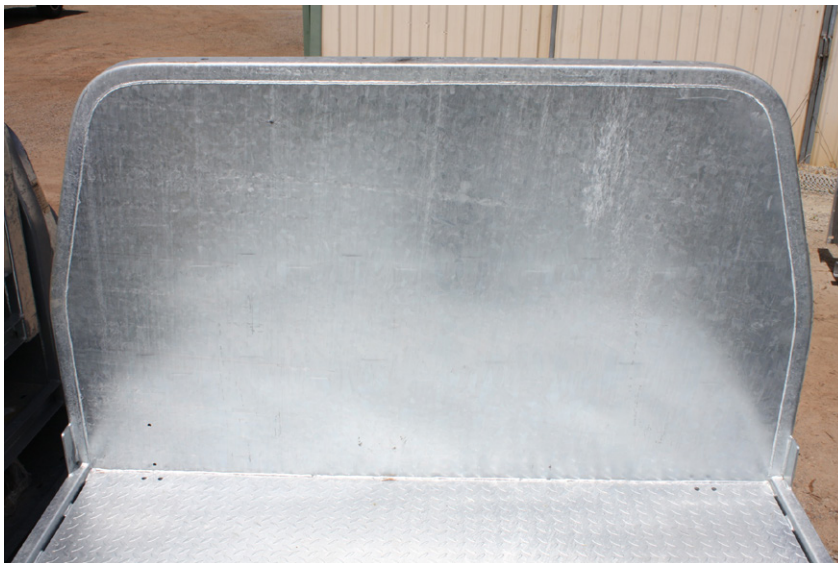
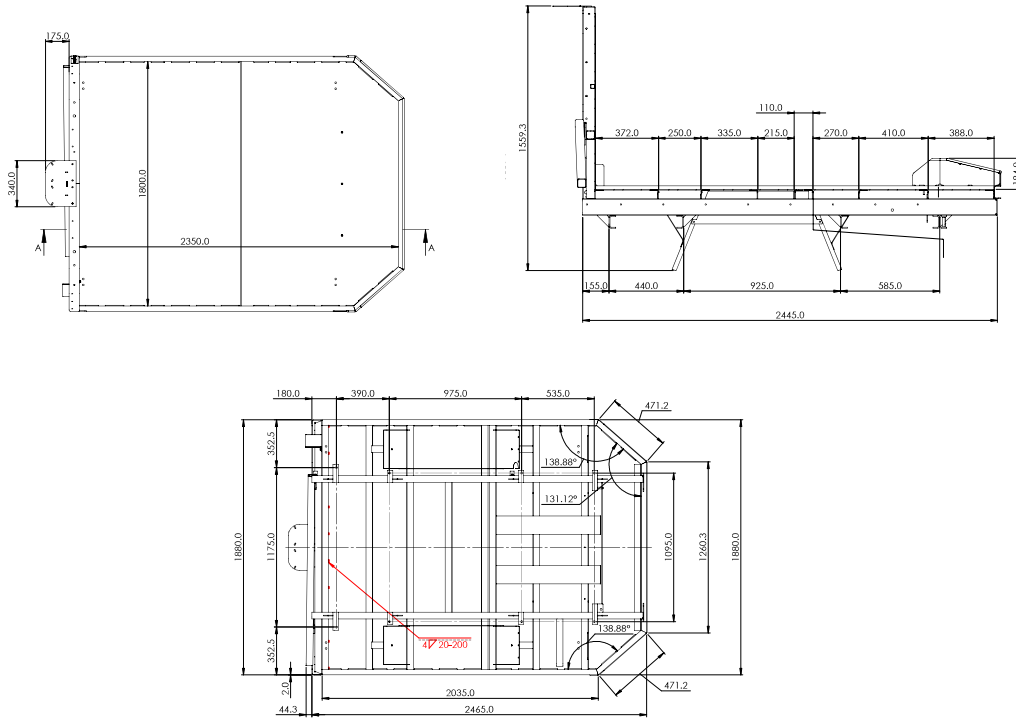

# MINE VEHICLE TRAYS



**ROPS CERTIFIED 79-SERIES TRAY WITH DROP SIDES**



The ELM 79-Series Light Vehicle Tray With Drop Sides is compliant to ISO 3471:2008 and is ROPS certified. This tray is purpose-built to endure challenging mining conditions in both underground or open cut mines. Our newly designed drop sides provide added convenience for transporting goods, ensuring loads can be quickly placed in the tray from any angle. The tray is also fully hot-dip galvanized for unmatched durability and longevity.

## Features

- ◆ ISO 3471:2008 ROPS certified
- ◆ Hot dip galvanized
- ◆ Direct bolt on to Toyota LandCruiser vehicles
- ◆ Mud guard kit included
- ◆ Drop sides to allow easy access to the tray

SERIES	MATERIAL	FINISH	WEIGHT	DIMENSIONS (MM)	CERTIFICATION
2275-291	Mild Steel	Hot Dip Galvanized	360 Kg	2642 x 1880 x 1565.8	ISO 3471:2008

## Engineering & Dimensions

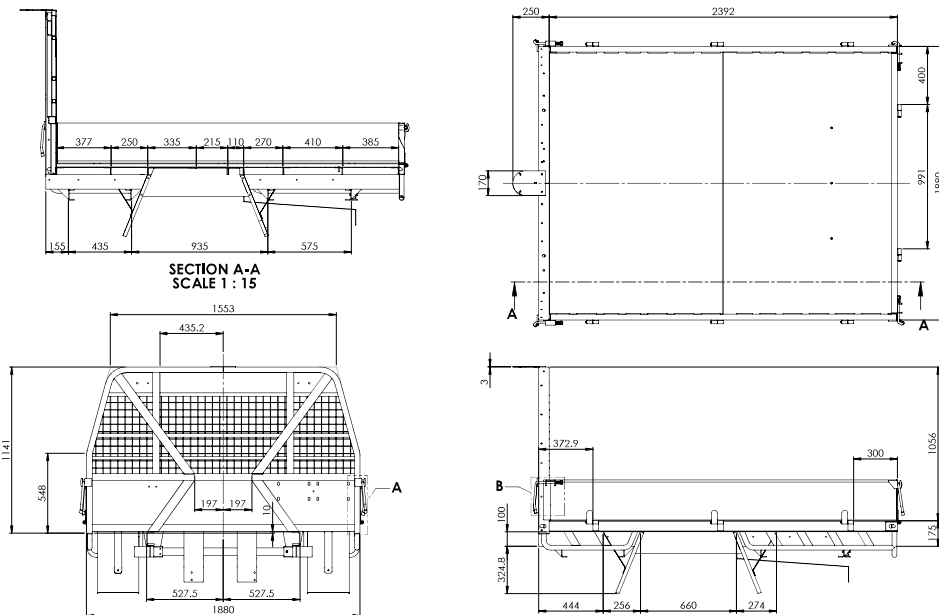

# MINE VEHICLE TRAYS



## HILUX SURFACE TRAY

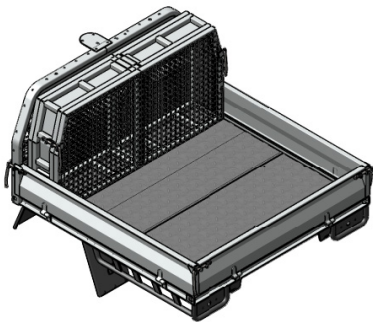

The ELM Hilux Surface Tray is compliant to ISO 3471:2008 and is ROPS certified. This product is meticulously engineered to withstand the demanding conditions of mining operations. Our innovative design featuring drop sides offers both comfort and improved usability during goods transportation. In addition, this product comes in an appealing white color as standard with a high-build black underbody, combining aesthetics with robust functionality.

### Features

- ◇ ISO 3471:2008 ROPS certified
- ◇ Hot dip galvanized
- ◇ Direct bolt on to Dual Cab Toyota Hilux vehicles
- ◇ Mud guard kit included

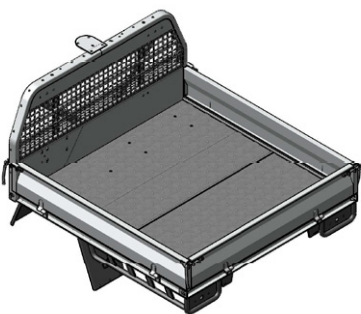

SERIES	MATERIAL	FINISH	WEIGHT	DIMENSIONS (MM)	CERTIFICATION
2275-266AGDC	Mild Steel	Painted White With Black Underbody	135 Kg	1982 x 1870 x 1388	ISO 3471:2008



## Engineering & Dimensions

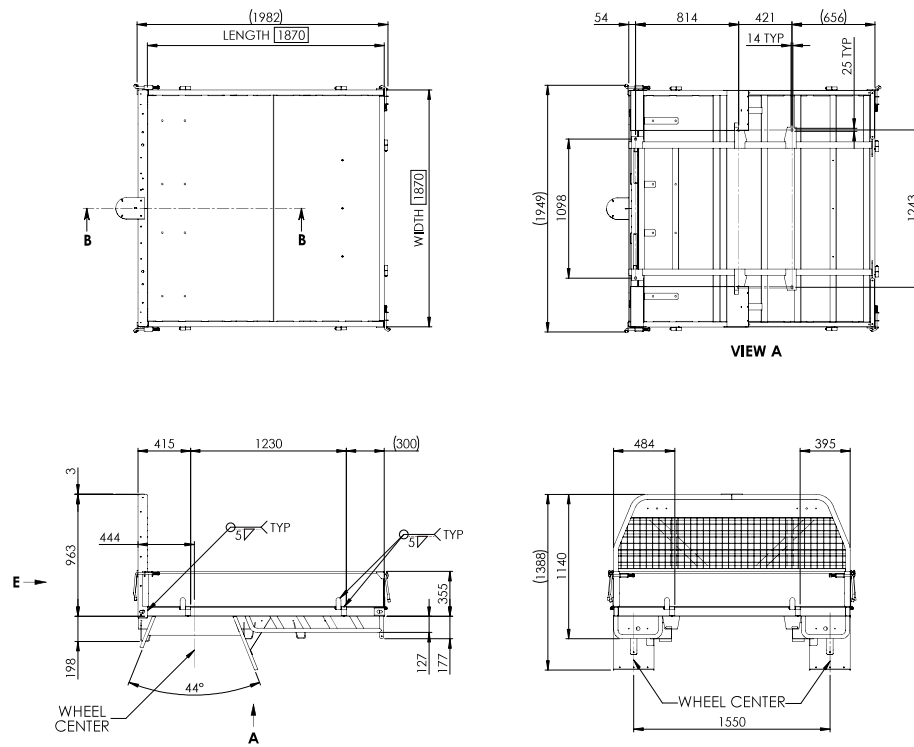

# MINE VEHICLE ACCESSORIES

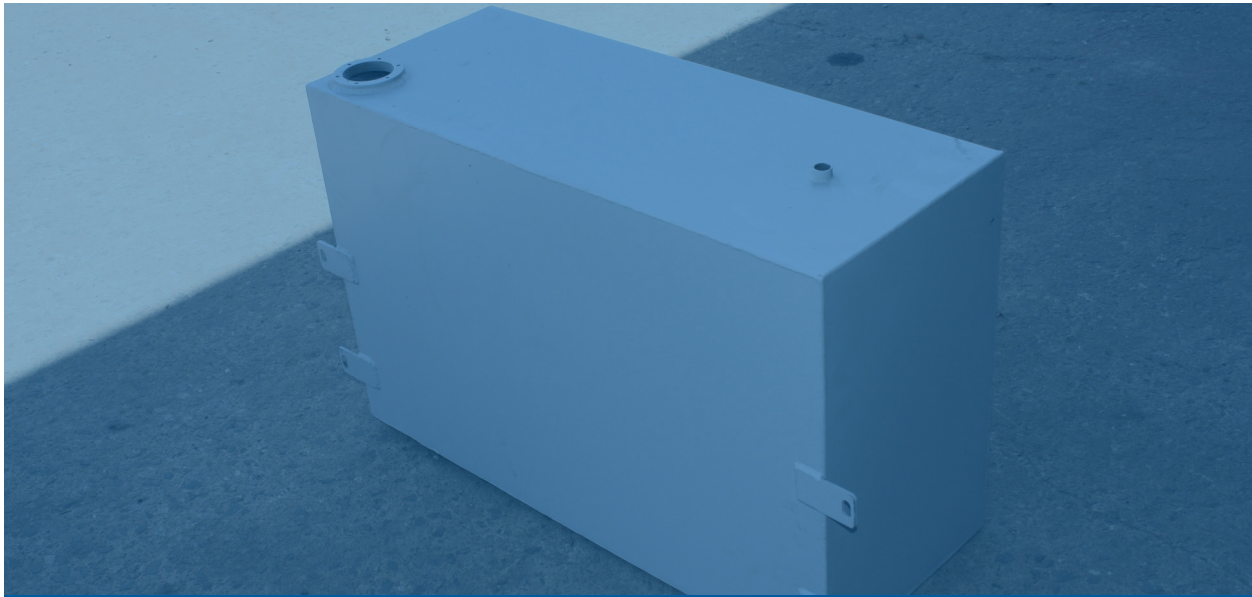

LV FITTERS TRAY- 100L OIL TANK

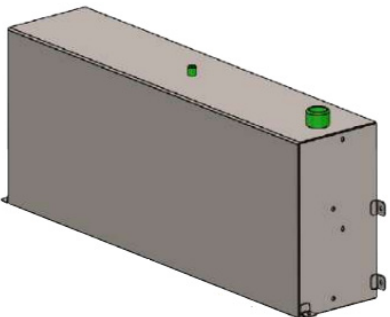
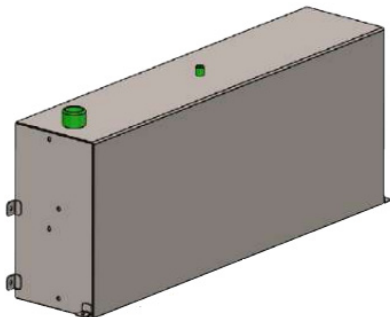

ELM's custom-built 100L Hydraulic Oil Tank are meticulously designed to meet the unique needs of fleet maintenance vehicles. This tank offers an efficient solution for hydraulic oil cartage, ensuring your team has the tools they need to get the job done. With its carefully tailored design, it seamlessly integrates into your maintenance vehicle, providing ample capacity for hydraulic oil storage. This product can be used with ELM's range of light vehicle trays, or can be equipped to any other vehicle.

## Features

- ◇ Seamless installation
- ◇ Universally compatible with all tray types
- ◇ Professional powder coating
- ◇ Enhanced with an additional breather point
- ◇ 100L capacity
- ◇ Durable mild steel construction

SERIES	MATERIAL	FINISH	WEIGHT	DIMENSIONS (MM)	CERTIFICATION
2275-192VFT-S009	Mild Steel	Powder Coated	40.58 Kg	480 x 345	N/A

## Engineering & Dimensions

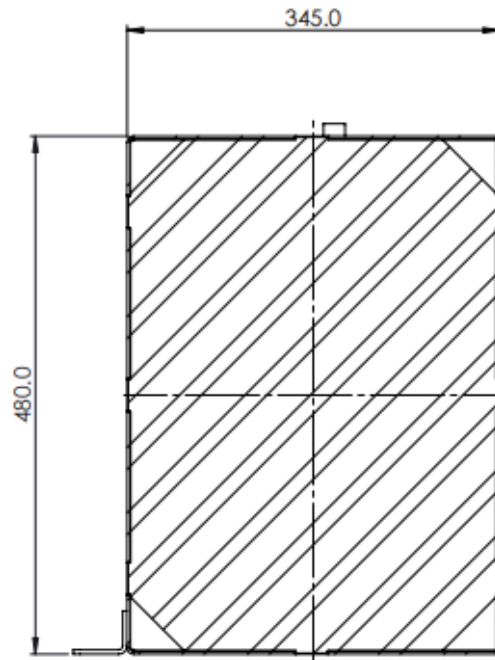

# MINE VEHICLE ACCESSORIES

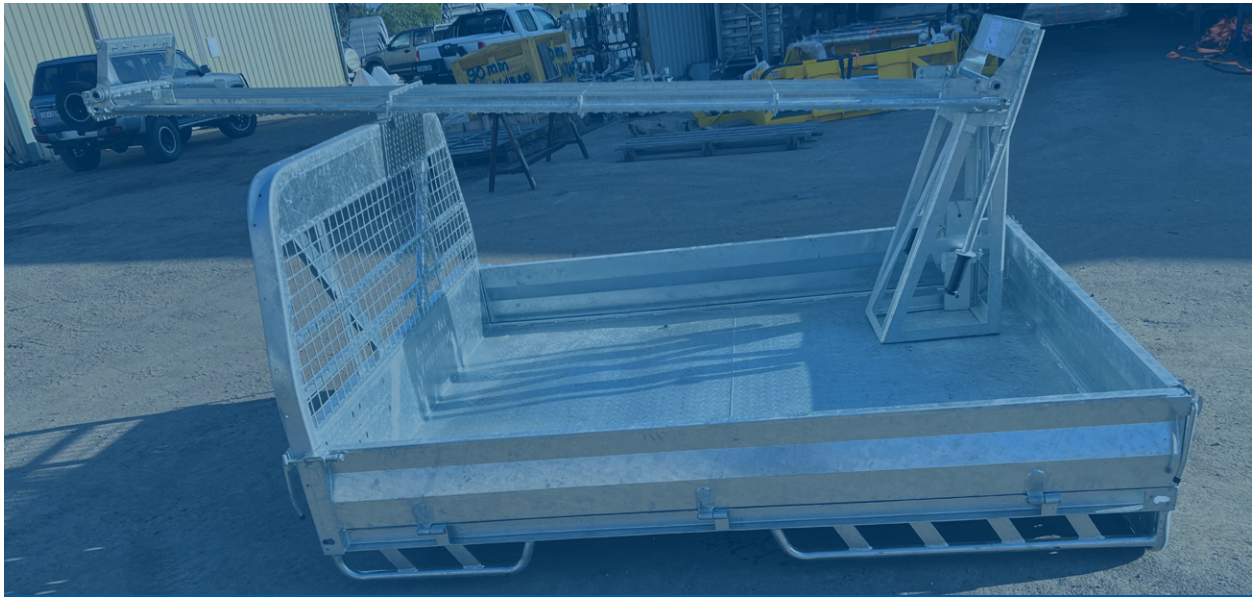

LV DRILL STEEL HOLDER

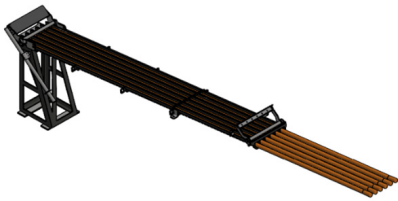

ELM's specially designed Drill Steel Holder provides secure storage and transportation of valuable drill steels. Featuring a level lock and pin-in-place system, it guarantees the prevention of any steel slippage during transportation. With a generous capacity for up to six drill steels, this holder is thoughtfully engineered and comes complete with a hot-dip galvanized finish for long-lasting durability. This essential piece of equipment guarantees that your drill steels remain in optimal condition, ensuring they are always prepared for your operational needs.

## Features

- ◇ Streamlined installation process
- ◇ Universally compatible with all tray types
- ◇ Hot dip galvanized
- ◇ Durable mild steel construction
- ◇ Holds 6 drill steels
- ◇ Level lock and pin-in-place system

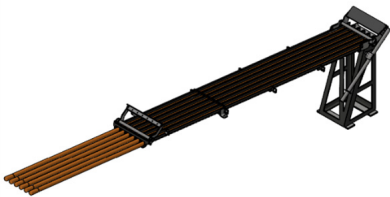

SERIES	MATERIAL	FINISH	WEIGHT	DIMENSIONS (MM)	CERTIFICATION
2275-178	Mild Steel	Hot Dip Galvanized	395.4 Kg	5111 x 570 x 1452	N/A

## Engineering & Dimensions

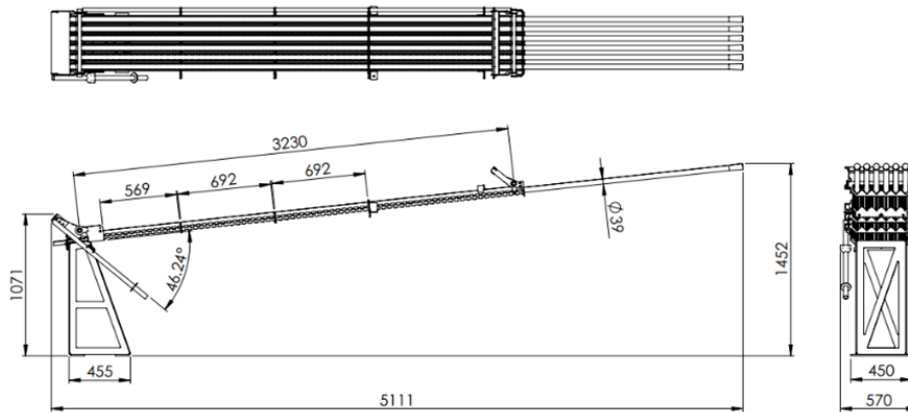

# MINE VEHICLE ACCESSORIES

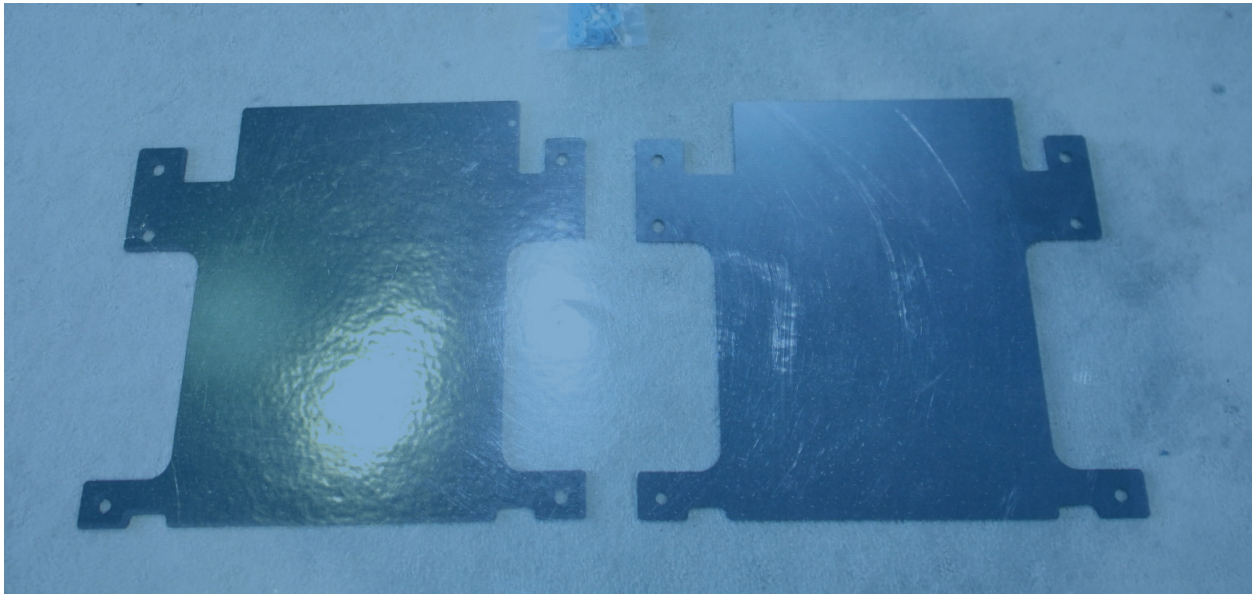

SINGLE CAB INTRUSION PLATES RHD

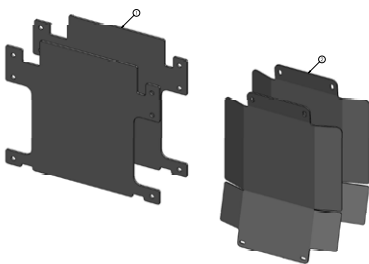
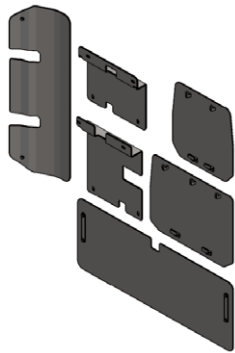

ELM's specially designed intrusion plates represent a significant enhancement in seat safety, and are specifically engineered to fortify and protect the under and rear areas of vehicle seats. Crafted with precision, these intrusion plates serve as a reliable safeguard, reinforcing your vehicle's seating structure against potential impacts and intrusions from external forces. They are a vital addition which ensures the safety and integrity of your vehicle's occupants in the event of unforeseen accidents or collisions.

## Features

- ◇ Streamlined installation process
- ◇ Enhanced safety: Strengthens seat integrity
- ◇ Added protection: Guards against rear and underneath impacts
- ◇ Structural reinforcement: Strengthens seat structure
- ◇ Durable mild steel construction

SERIES	MATERIAL	FINISH	WEIGHT	DIMENSIONS (MM)	CERTIFICATION
2275-114FL	Mild Steel	Powder Coated	53.5 Kg	443 x 390 343.9 x 450.1	N/A

## Engineering & Dimensions

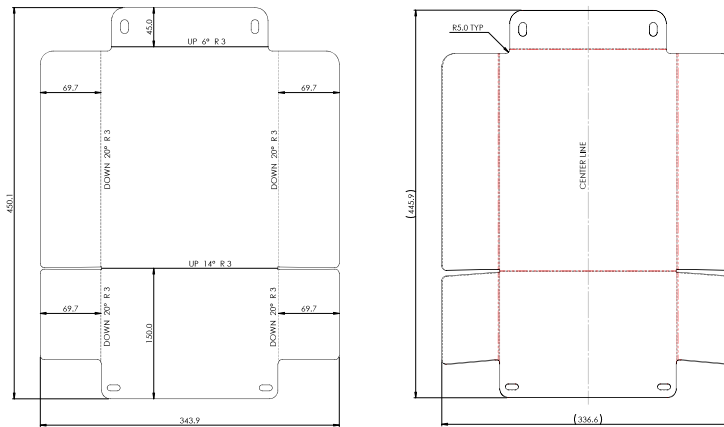
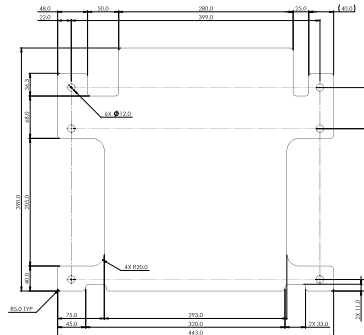

# MINE VEHICLE ACCESSORIES

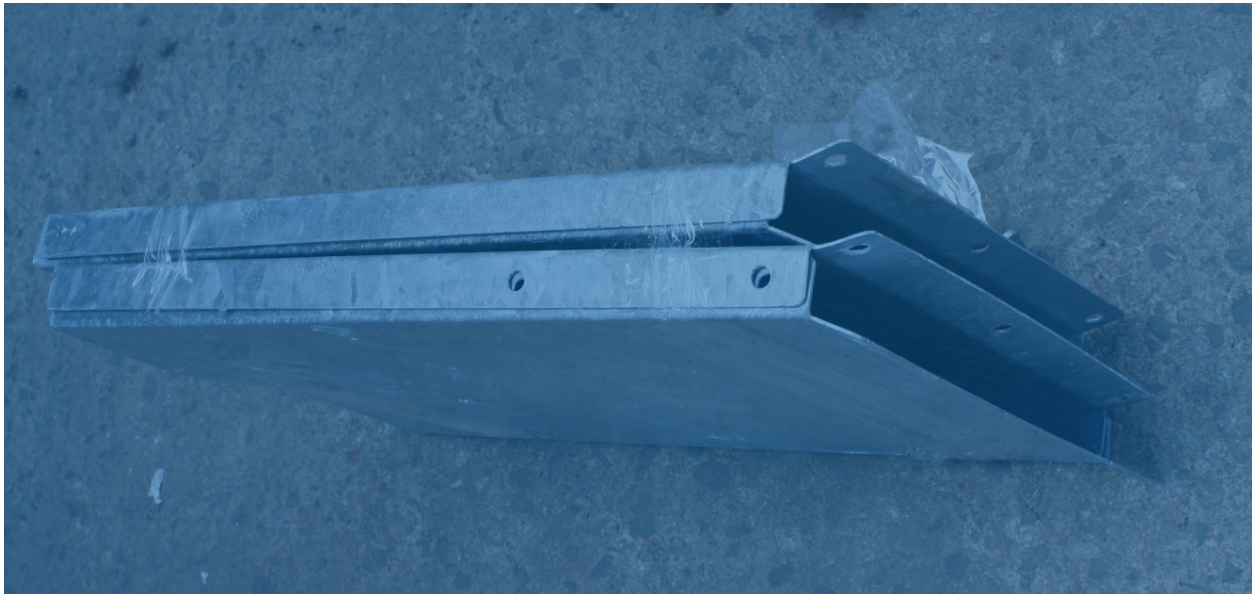

## STANDARD LV TRAY MUD GUARD SET

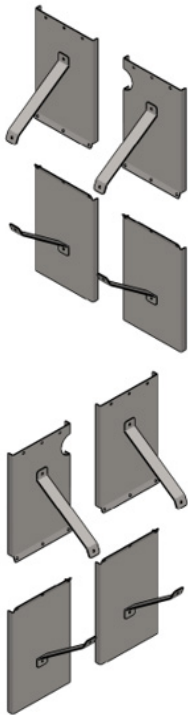

Constructed from hot-dip galvanized steel, these steel mud guards are not only remarkably easy to install on any ELM tray, but they also excel in protecting vehicles, particularly in high-corrosion environments. The hot-dip galvanization process ensures that these mud guards remain resilient against rust and environmental damage, effectively extending their lifespan. By acting as a shield, they deflect debris and moisture, preventing impacts to sensitive vehicle components such as brake systems and electrical connections. This translates to reduced maintenance costs, as well as enhanced safety and longevity for the vehicle, making steel mud guards a smart choice for any fleet operating in challenging conditions.

### Features

- ◇ Streamlined installation process
- ◇ Universally compatible with all tray types
- ◇ Hot dip galvanized
- ◇ Durable mild steel construction

### Available Packages:

- ◇ Set of 4 LV Tray Mud Guards

SERIES	MATERIAL	FINISH	WEIGHT	DIMENSIONS (MM)	CERTIFICATION
2275-227	Mild Steel	Hot Dip Galvanized	9 Kg	285 x 473.2mm x 290.0 285 x 473.2mm x 273.8	N/A



## Engineering & Dimensions

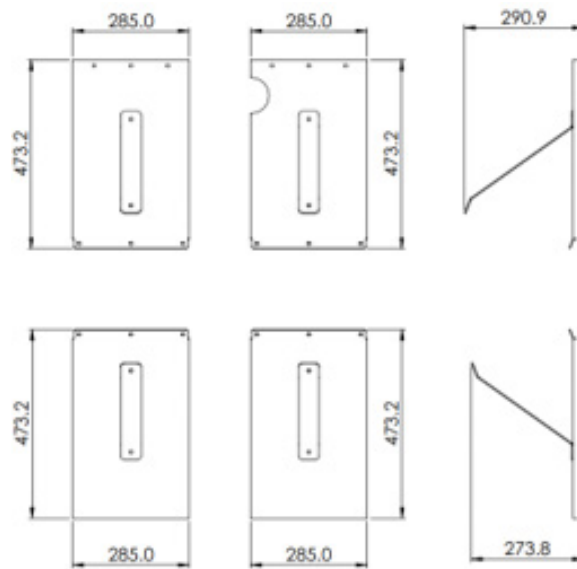

# MINE VEHICLE ACCESSORIES



## TRAY HAND RAIL SET

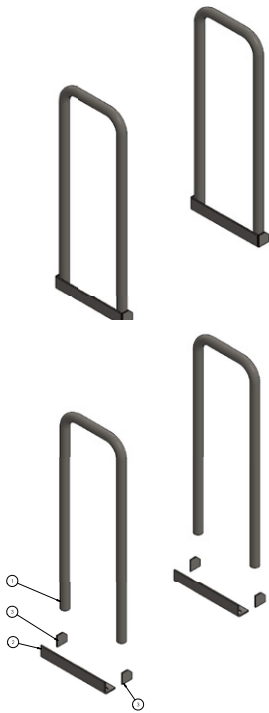

The installation of handrails on a light vehicle tray is a proactive safety measure, eliminating the risk of falls by offering three reliable points of contact. These handrails are hot-dip galvanized for exceptional durability, ensuring long-lasting protection against corrosion from environmental factors. Beyond bolstering safety for personnel working on the tray, these handrails streamline access, making loading and unloading processes more efficient. This combination of enhanced safety and operational ease results in a more secure and productive workspace for your team.

### Features

- ◇ Streamlined installation process
- ◇ Universally compatible with all tray types
- ◇ Hot dip galvanized
- ◇ Durable mild steel construction

### Available Packages:

- ◇ Set of 2 Tray Hand Rails

SERIES	MATERIAL	FINISH	WEIGHT	DIMENSIONS (MM)	CERTIFICATION
2275-229	Mild Steel	Hot Dip Galvanized	2.7 Kg	239 x 212 x 656.5	N/A

# Engineering & Dimensions

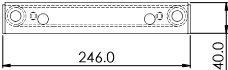
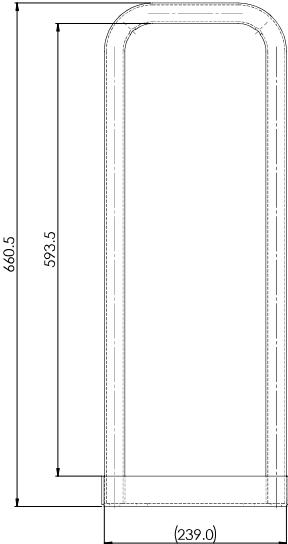

# LIFTING EQUIPMENT

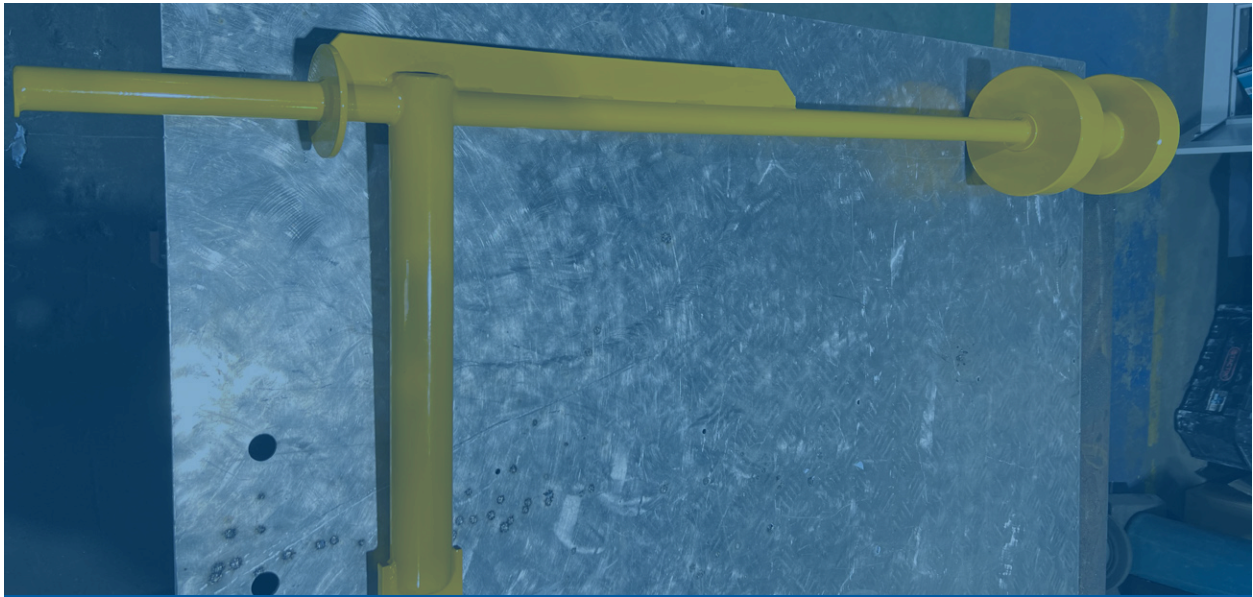

KESSLER LIFTING TOOL

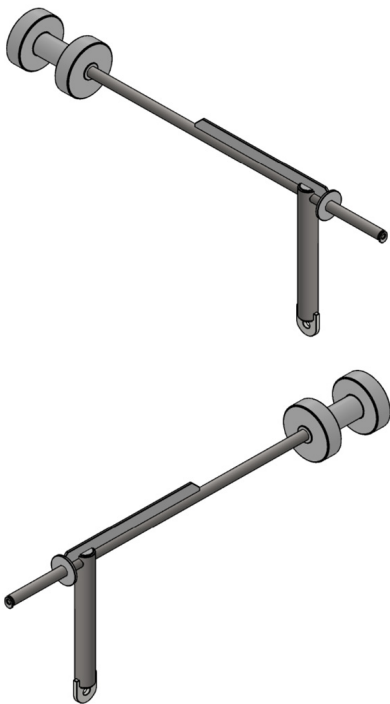

ELM's meticulously tested and proven Planetary Lifting Tool boasts precise alignment capabilities, making it the ideal choice for the removal and installation of Kessler planetaries. Equipped with a built-in counterweight, it ensures optimal stability during these crucial procedures. Additionally, for enhanced visibility and safety on the job site, this tool is powder-coated in a vibrant safety yellow, ensuring it remains highly visible and easily identifiable amidst other machinery and equipment.

## Features

- ◆ Rigorously tested for precision during Kessler work
- ◆ Equipped with a built-in, hand adjusted counterweight for stability
- ◆ Powder-coated in vibrant safety yellow for high visibility
- ◆ Demonstrated reliability through extensive testing
- ◆ Prioritizes safety during planetary operations

SERIES	MATERIAL	FINISH	WEIGHT	DIMENSIONS (MM)	CERTIFICATION
2275-126	Mild Steel	Powder Coated Safety Yellow	23.5 Kg	1254 x 152.1 x 472.7	N/A

## Engineering & Dimensions

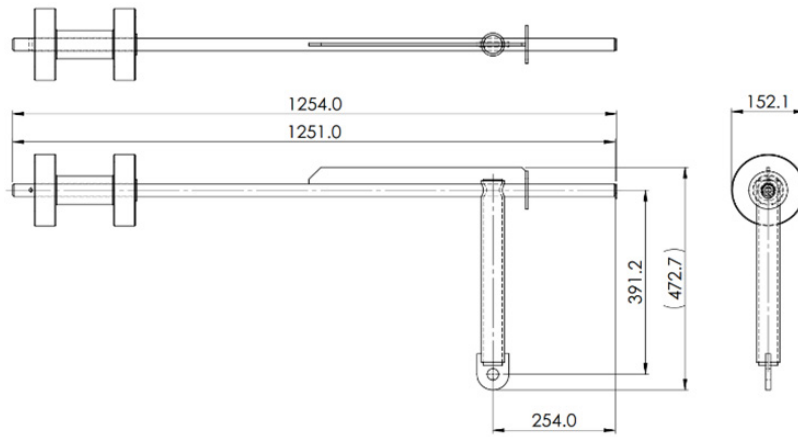

# LIFTING EQUIPMENT



## BUCKET TEETH LIFTING TROLLEY



Manual handling of G.E.T components presents a notable risk for back injuries. ELM's lifting trolley provides a mechanical solution for the safe replacement of bucket teeth on any bucket type. Its exceptional maneuverability and user-friendly hand adjustment feature empowers operators with precise control, ensuring a safe and efficient process when removing and installing G.E.T components. This ergonomic lifting trolley is an indispensable tool for efficient and safe G.E.T maintenance.

### Features

- ◇ Multipurpose functionality
- ◇ Powder-coated safety yellow
- ◇ Exceptional durability
- ◇ Robust mild steel and aluminum construction
- ◇ Enhances safety and reduces the risk of back injuries

SERIES	MATERIAL	FINISH	WEIGHT	DIMENSIONS (MM)	CERTIFICATION
2275-210	Mild Steel, Aluminium	Powder Coated Safety Yellow	127 Kg	1874.4 x 1171 x 2066.3	N/A

## Engineering & Dimensions

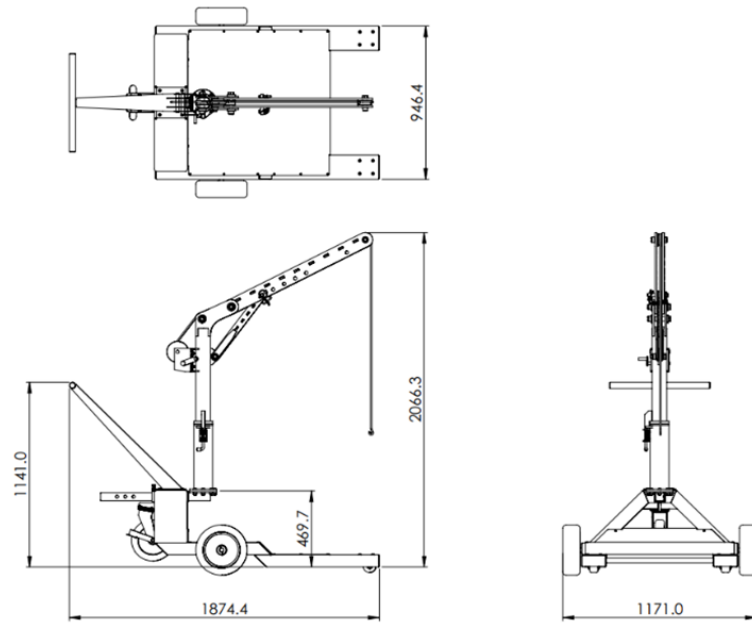

# SANDVIK JUMBO ACCESSORIES



SANDVIK JUMBO HOSE TREE LOOM CLAMP



Engineered to seamlessly accommodate all development drill models, ELM's clamp system provides essential reinforcement for the main hose loom. Its design facilitates a neatly guided path alongside the rail and offers effortless accessibility through a secure three-bolt clamping mechanism. This innovative clamp system ensures not only efficient hose management but also minimizes wear and tear, ultimately contributing to the prolonged lifespan of your equipment. Additionally, its versatile design and adaptability to various drill models make it a valuable and cost-effective addition to your drilling operations.

## Features

- ◇ Available in powder-coated red or orange
- ◇ Constructed from robust 350-grade steel
- ◇ Durable, wear-resistant design for extended equipment life
- ◇ Versatile compatibility with all development drill models
- ◇ Streamlined installation process

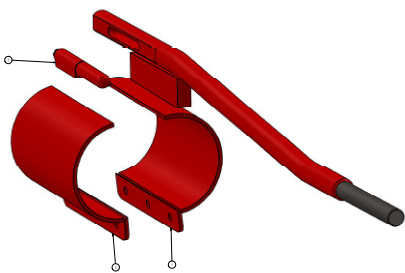

SERIES	MATERIAL	FINISH	WEIGHT	DIMENSIONS (MM)	CERTIFICATION
2275-386 LH/RH	C350	Powder Coated	19 Kg	974.1 x 146.1 x 223.6	N/A



## Engineering & Dimensions

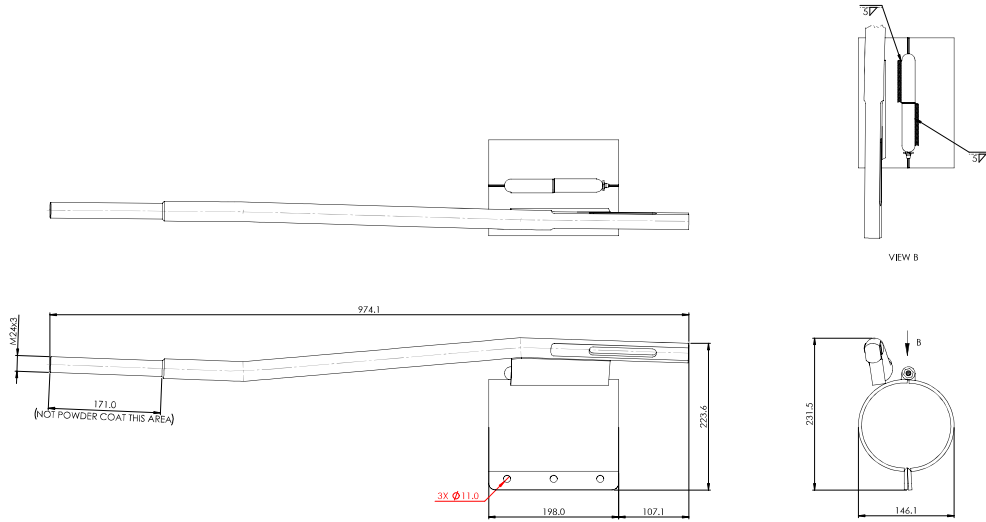

# SANDVIK JUMBO ACCESSORIES

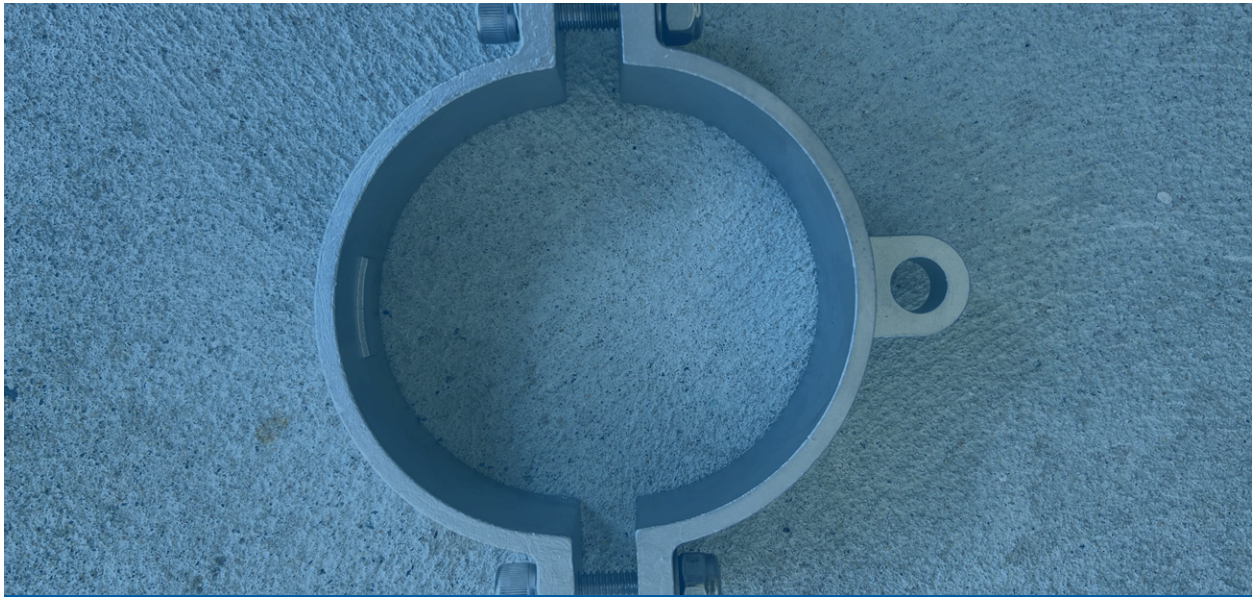

**SANDVIK JUMBO HOSE LOOM HANGER CLAMP**

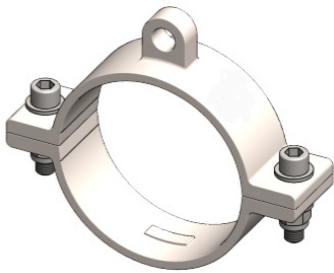

This innovative clamp system replaces the conventional sling method of suspending a hose loom, offering an organized and efficient solution for securing the primary loom. Specifically designed for Sandvik Development drills, it elevates the loom in proximity to the boom, eliminating the risk of looms hanging too low and coming into contact with the ground. This method reduces wear and tear on hose looms, extending the lifespan of your assets.

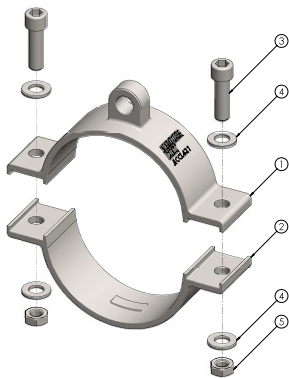

## Features

- ◆ Tailored to fit seamlessly with Sandvik drill models
- ◆ Adjustable for precise settings
- ◆ Secure lock-in-place mechanism
- ◆ Constructed from robust stainless steel
- ◆ Minimizes wear and tear on hose looms, increasing asset longevity

SERIES	MATERIAL	FINISH	WEIGHT	DIMENSIONS (MM)	CERTIFICATION
2275-405	Stainless Steel	Raw	1.7 Kg	168 x 200.4 x 168	N/A

## Engineering & Dimensions

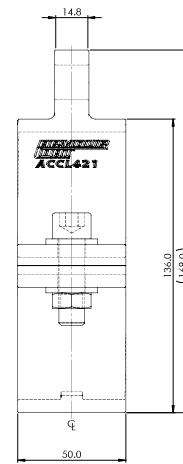
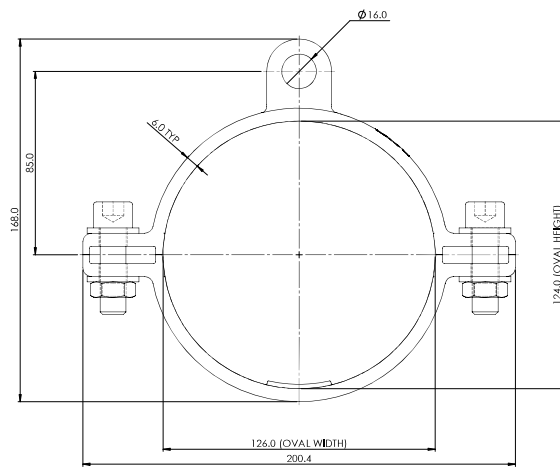
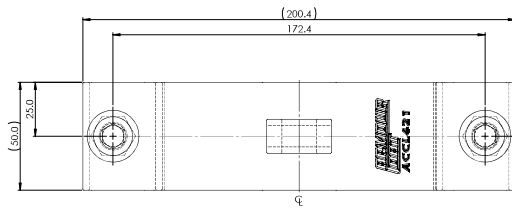

# GET IN TOUCH:



0438 572 451



[sales@elmequipment.com.au](mailto:sales@elmequipment.com.au)



34 Harries Way, Pinjarra  
WA 6208



Certified Explosive Boxes



Mine Vehicle Accessories



Drill Rig Accessories



Lifting Equipment



Sandvik Jumbo Accessories

**ELM quality mining products**